

© DEN HARTOG INDUSTRIES, INC.

Copyright. All information furnished within this document, electronic file or design correspondence is the property of Den Hartog Industries, Inc. and shall not be used, disclosed to others or copied without the expressed written consent of Den Hartog Industries, Inc.

CB086-15ST

F

KEY	PART NUMBER	DESCRIPTION	QTY.	
1	CB086-15ST-1	3/8" X 2" MILD STEEL FLAT	4	(E)
2	CB086-15ST-2	3" MILD STEEL CHANNEL (LEFT)	1	(D)
3	CB086-15ST-3	3" MILD STEEL CHANNEL (RIGHT)	1	(D)
4	CB086-15ST-4	3" MILD STEEL CHANNEL	2	(E)
5	CB086-15ST-5	1" SIZE TUBING	6	(E)
6	CB086-15ST-6	14 GA MILD STEEL SHEET (HOLES)	1	(D)
7	CB086-15ST-7	14 GA MILD STEEL SHEET	1	(D)
8	CB086-15ST-8	3" MILD STEEL CHANNEL	1	(D)
9	12521	CB ϕ 12" RING STAND	1	(C) (F)
10	12750	1/4" X 4" X 4" LEG PAD	6	(D)
11	CB086-15ST-9	LEG-POWDER COAT	2	(F)

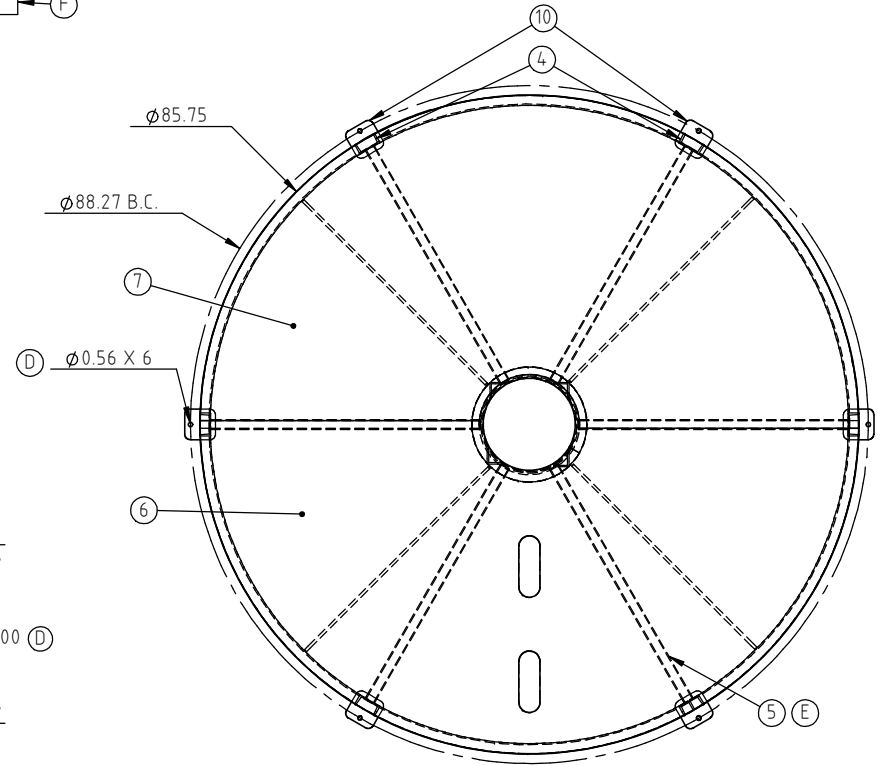
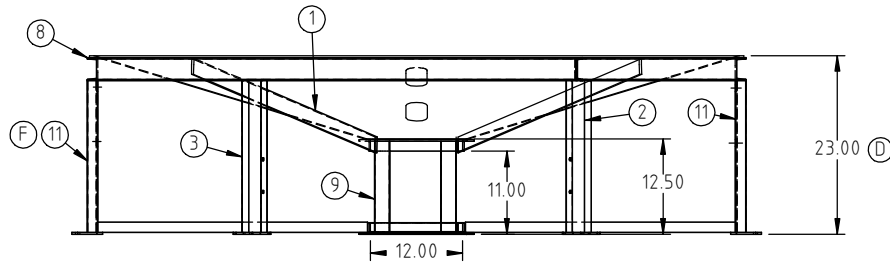

F	HOLES FOR POWDER COATING ADDED TO TWO LEGS, PARTS TABLE FORMAT ADJUSTED	ADH 7/22/11	2254
E	COMPONENT TABLE UPDATED, TUBE SHORTENED 0.13"	ADH 7/2/10	2051
D	MATERIAL P.N. CORRECTED, 12750 WAS SJC85/90ST, 282.00 WAS 280.50, 19.75 WAS 20.00, ϕ 0.56 WAS ϕ 0.625, WEIGHT AND FINISH ADDED	ADH 1/26/10	1995
C	12521 WAS SJC85/90ST-2	ADH 12/7/07	1542
B	PN WAS CB085-15ST	NVE 7/31/06	
A	ADDED B.O.M.	NVE 5/17/06	
REV	DESCRIPTION	BY / DATE	CCN

DRAWN / DATE	MATERIAL
ADH 6/19/07	
APPRD. / DATE	
REH 6/28/07	

ALL DIMENSIONS ARE IN DECIMAL INCHES
TOLERANCES UNLESS OTHERWISE SPECIFIED

POLYETHYLENE	METAL DECIMAL \pm .125" FRACTION \pm 1/4" ANGLE \pm 1°
\pm 1% @ 68°F	

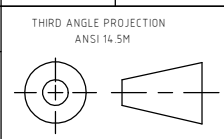

SHOT WEIGHT:
SHIPPING WEIGHT:
FINISH:

360.00 LBS

POWDER COATING,
BLACK TILE, 40012

NOTES:



Den Hartog
INDUSTRIES, INC.

Acra Roto-Mold Injection Molding Blow Molding Sowjoy
4010 HOSPERS DRIVE S. BOX 425, HOSPERS, IOWA 51238-0425

DESCRIPTION	CONE BOTTOM STAND FOR ϕ 86" 15° TANKS	
SCALE	N.S.	PART NO. CB086-15ST