

© DEN HARTOG INDUSTRIES, INC.

Copyright. All information furnished within this document, electronic file or design correspondence is the property of Den Hartog industries, Inc. and shall not be used, disclosed to others or copied without the expressed written consent of Den Hartog Industries, Inc.

ITEM NO.	PART NUMBER	DESCRIPTION	QTY.
1	12615	TOTE SKID LEG WELDMENT	4
2	12503	BOLT, 3/8" X 1" SS	16 *
3	11094	WASHER, 3/8" X 1" OD FLAT SS	16 *
4	10223	NUT, 3/8" STAINLESS NYLOK	16 *
5	ST024-LG	INSTRUCTIONS	1 * (A)

\* INCLUDED IN HARDWARE BAG

ST024-LG

A

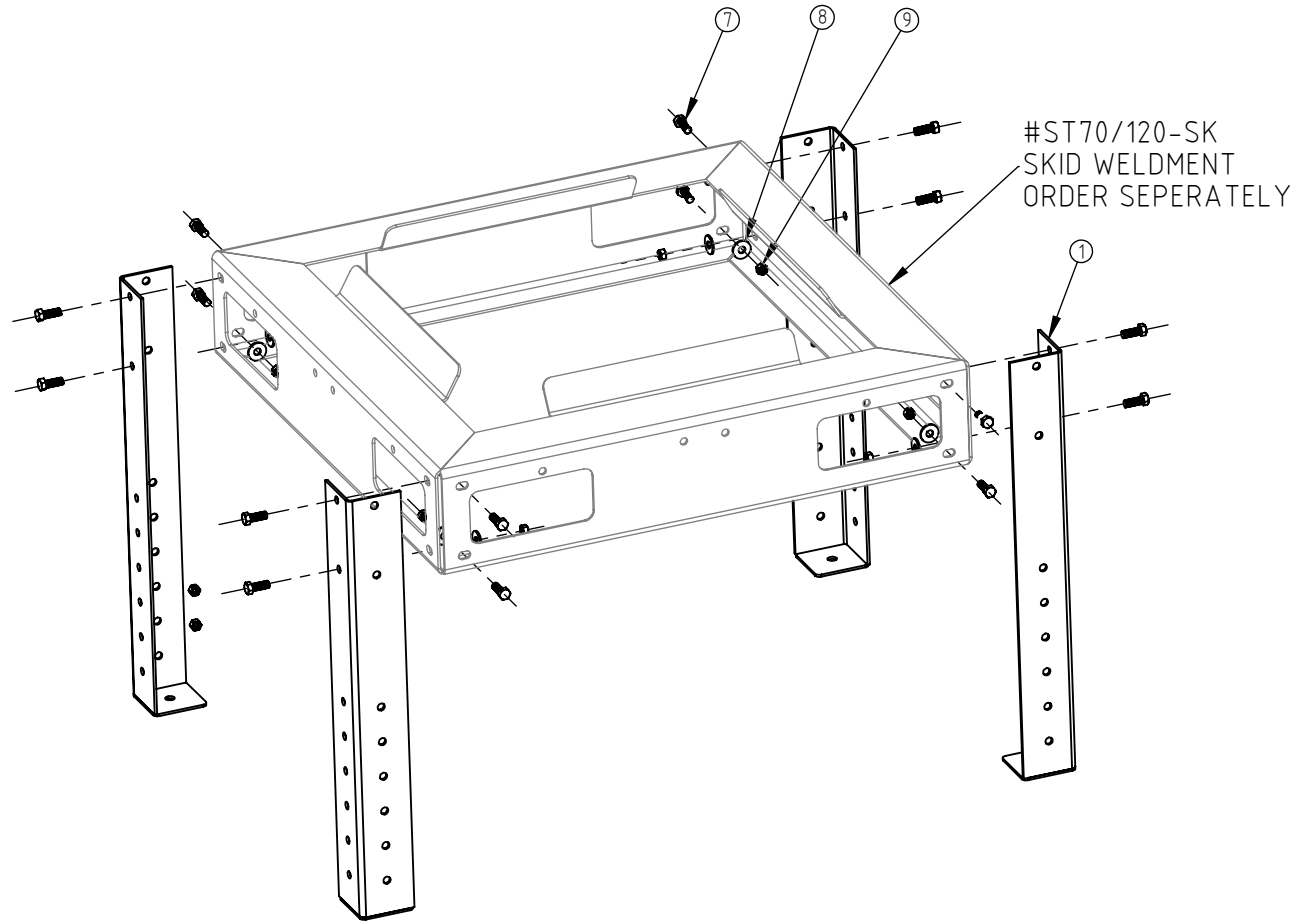

				DRAWN / DATE ADH 11/26/08	MATERIAL
A	ST024-LG WAS ST70/120-LG	ADH 4/18/11	2207	APPRD. / DATE REH 1/6/09	
REV	DESCRIPTION	BY / DATE	CCN		
ALL DIMENSIONS ARE IN DECIMAL INCHES TOLERANCES UNLESS OTHERWISE SPECIFIED		THIRD ANGLE PROJECTION ANSI 14.5M		SHOT WEIGHT:	NOTES:
POLYETHYLENE ±1% @ 68°F		METAL DECIMAL ± .125" FRACTION ± 1/4" ANGLE ± 1°		SHIPPING WEIGHT: 24 LB.	
				FINISH:	



**Den Hartog**  
INDUSTRIES, INC.

Ace Roto-Mold Injection Molding Blow Molding Sowjoy

4010 HOSPERS DRIVE S. BOX 425, HOSPERS, IOWA 51238-0421

DESCRIPTION	35, 70 AND 120 GALLON TOTE SKID LEG KIT	
SCALE	N.S.	PART NO. (A) ST024-LG